

THIS DRAWING IS UNPUBLISHED. RELEASED FOR PUBLICATION
 © COPYRIGHT - By - ALL RIGHTS RESERVED.

LOC		DIST		REVISIONS			
P	LTR	DESCRIPTION		DATE	DWN	APVD	
AF	50	AD	REVISED PER ECR-12-013445	18OCT12	KH	PD	

- 1 CONTINUOUS STRIP ON REELS
- △2 MAX FIRST INSERTION FORCE, 88.96 NEWTON [20 LBS] USING GAGE 100505.
- 3 WIRE SIZE IS #14-10 AWG
- 4 INSULATION RANGE IS 3.81-5.08 [.150-.200] DIA
- 5 MATING TAB THK IS 0.81±0.025 [.032±.001]
- △6 FOREIGN PRODUCTION ONLY
- △7 OBSOLETE PARTS: OBSOLETE CIS STREAMLINING PER D.RENAUD/D.SINISI

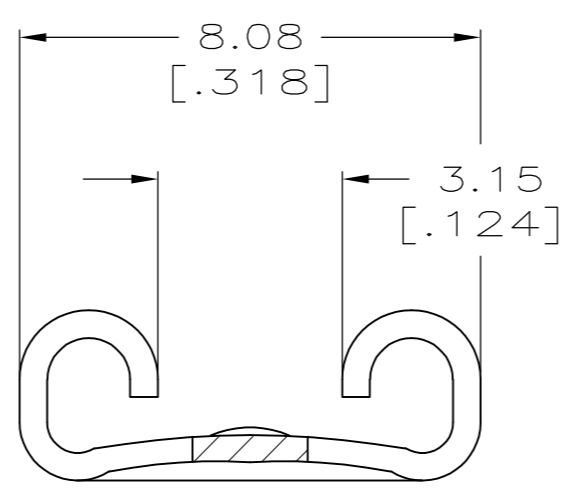
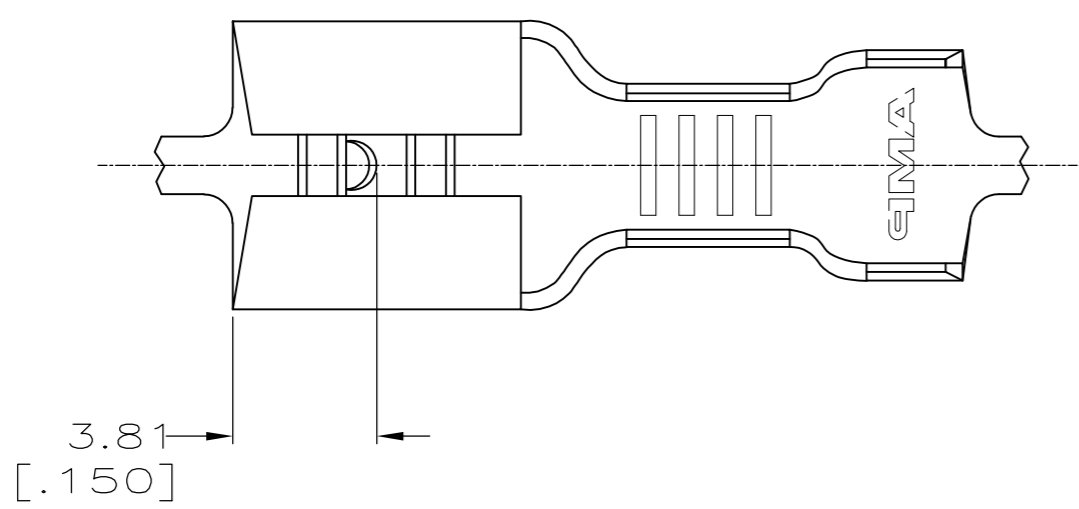

VIEW A-A
SCALE 10:1

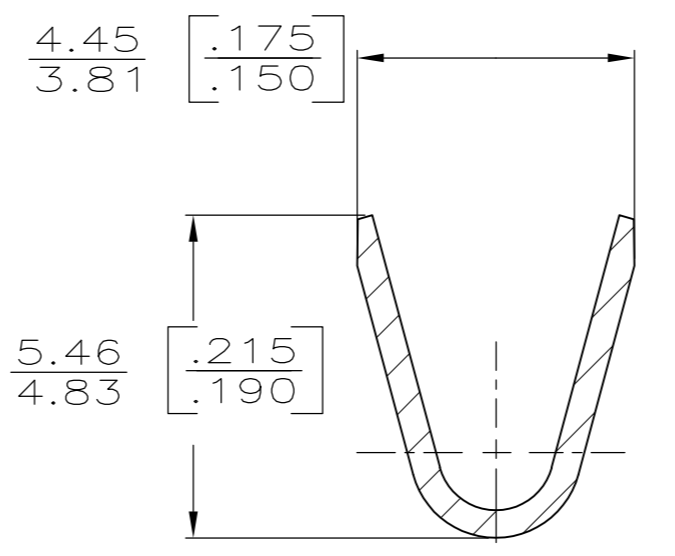
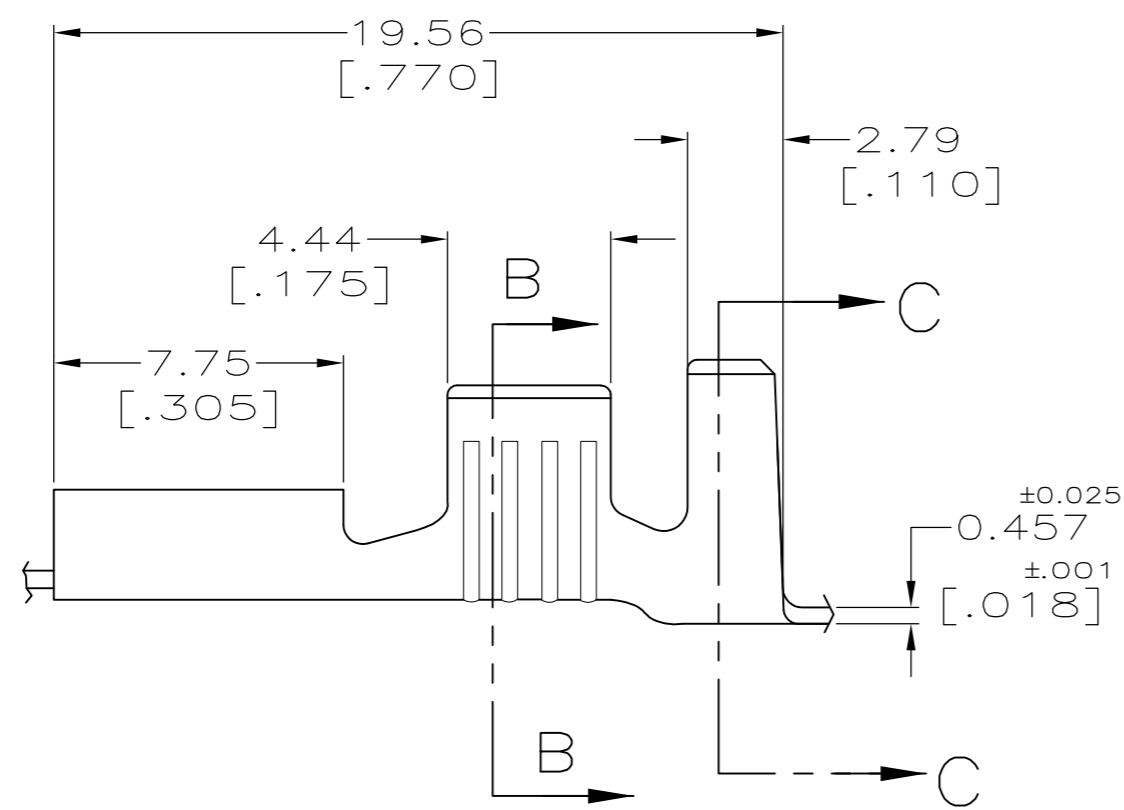

SECTION B-B
SCALE 8:1

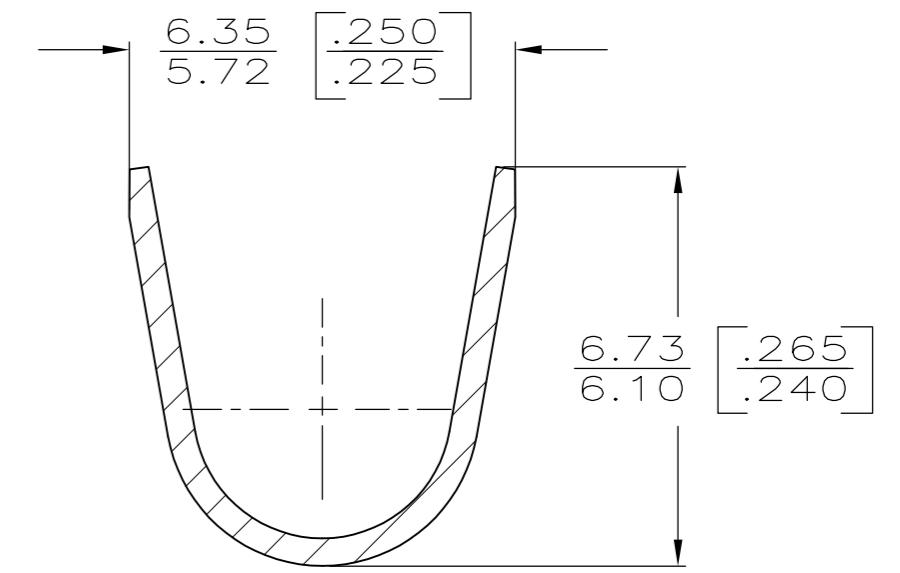

SECTION C-C
SCALE 8:1

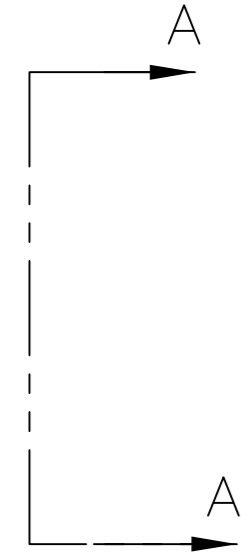

TYPE	WIDTH	STRIP LENGTH ±0.38 ±[.015]	TYPE	WIDTH	±.051 ±.002 HEIGHT	WIRE
F	5.33 [.210]	6.4 [.252]	F	3.30 [.130]	2.108 [.083]	2.0mm [14]
					2.413 [.095]	3.0mm [12]
					2.921 [.115]	5.0mm [10]
INSUL BARREL CRIMP	WIRE BARREL CRIMP					

FINISH	MATERIAL	PART NO.
△6 △7 OBSOLETE	SILVER	TEMP3 PHOS BRZ
	TIN	TEMP3 PHOS BRZ
OBSOLETE	-	TEMP3 PHOS BRZ
OBSOLETE	SILVER	TEMP4 BRASS
	TIN	BRASS
OBSOLETE	-	TEMP4 BRASS
	FINISH	MATERIAL
		PART NO.

THIS DRAWING IS A CONTROLLED DOCUMENT.

DWN	JR RUTH	7/10/89
CHK	MS FEHER	7/10/89
APVD	C MEYERS	7/10/89
PRODUCT SPEC		
APPLICATION SPEC		
WEIGHT	-	
CUSTOMER DRAWING		

TE TE Connectivity

RECEPTACLE, FASTON, .250 SERIES

SIZE	A2	CAGE CODE	00779	DRAWING NO	C=42437	RESTRICTED TO	-
SCALE	5:1	SHEET	1 of 1	REV	AD		